

Operation Manual



BHTP-601

Tissue Embedding System

Thank you for Choosing Biolab products. Please read the "Operating Instructions" and "Warranty" before operating this unit to assure proper operation.

Index

1. Safety.....	03
2. Instrument Specification	04
3. Instrument Components	05
4. Operation.....	06
5. Troubleshooting.....	11
6. Maintenance.....	13

01 Safety

1.1 Safety Matters

Please read these explicit rules. Act in violation of them can affect normal operation of the equipment, cause damage to the equipment or result in danger.

Use proper nominal supply voltage

The input power supply must have a good ground.

Install away from flammable and explosive objects

Never open instrument without authorization to prevent high voltage shock

Service should be done only by authorized personnel.

Check regularly the parameters showed during operation

Disconnect instrument from power supply after use

Use proper fuses

Use only proper power cord

Install the instrument away from any interference source

Equipment which needs heating must not be heated without liquid

1.2 Installation environment

(1) More than 20cm of space around the equipment for heat dissipation.

(2) Free of water-drop, steam, dust(including oily dust and flying dust)

(3) Free of corrosive, flammable and explosive gas and liquid

(4) Firm and without vibration

(5) Free of electromagnetic interference

(6) Ambient temperature and relative humidity at -10°C — 50°C and less than

90%,respectively

1.3 Maintenance and cleaning

(1) Before servicing and cleaning switch of the instrument and plug out the main plug.

(2) Before cleaning the hot surface wait unit all parts reach room temperature.]

(3) During cleaning don't allow any liquid to penetrate inside the instrument.

(4) Before cleaning defective fuse disconnect the instrument from the main plug. Do not use any fuses different from the value of original one.

02 Instrument Specification

2.1 Main Console specification

Nominal supply voltage: 220V/50Hz

Maximum power draw: 650VA

Working temperature: from ambient to 80°C increments 1°C

Capacity

Paraffin reservoir: 6.0 Lt

Cassette/mold tray: 1.6 Lt

Dimensions

Width: 600mm

Depth: 650mm

Height: 460mm

Weight: 30Kg

2.2 Cryo Console specification

Nominal supply voltage: 220V/50Hz

Maximum power draw: 200VA

Working temperature: from 0°C to -20°C increments 1°C

Dimensions

Width: 410mm

Depth: 580mm

Height: 440mm

Weight: 25Kg

2.3 Thermal Console specification

Nominal supply voltage: 220V/50Hz

Maximum power draw: 650VA

Working temperature: from ambient to 80°C increments 1°C

Capacity

Paraffin tray: 5Lt

Dimensions

Width: 410mm

Depth: 620mm

Height: 440mm

Weight: 13Kg

03 Instrument Components

3.1 Overview instrument part Main Consol

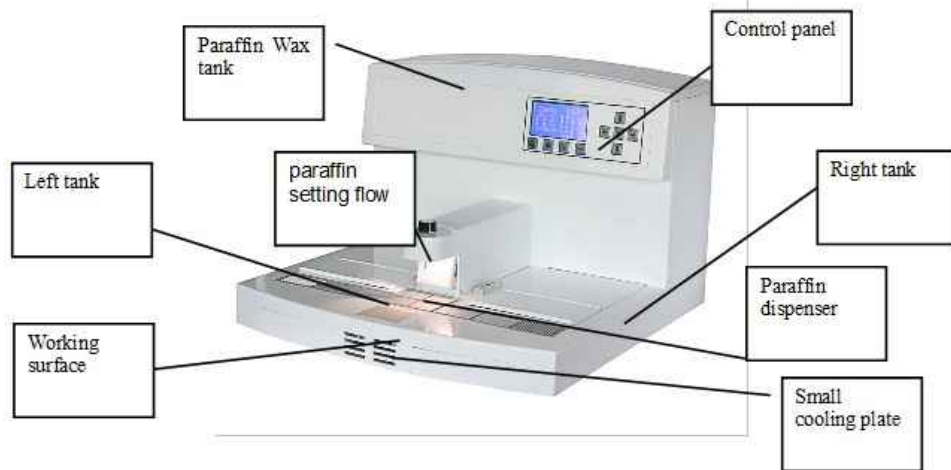

3.2 Overview instrument

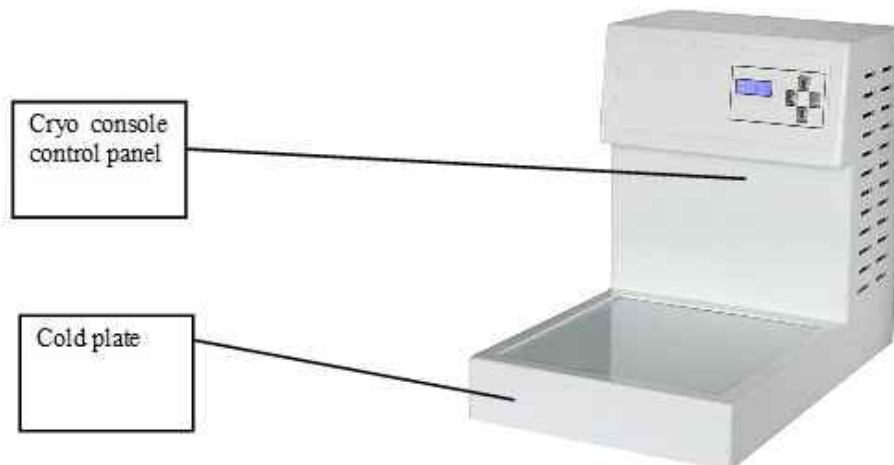

3.3 Overview instrument part Thermal Console

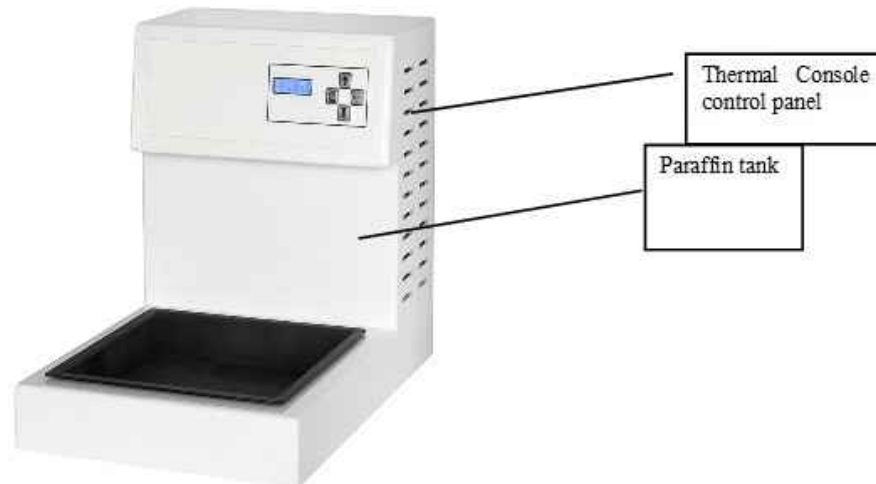

04 Operation

4.1 Function of keys



Press this key, to enter the set interface.



Press this key, to turn the next page.



Press this key, to move cursor right.



Press this key, to start the small cooling plate.

4.2 Connect instruments

Connect the Main console to the power supply, also insert the plug of the foot switch into the socket at the rear side.

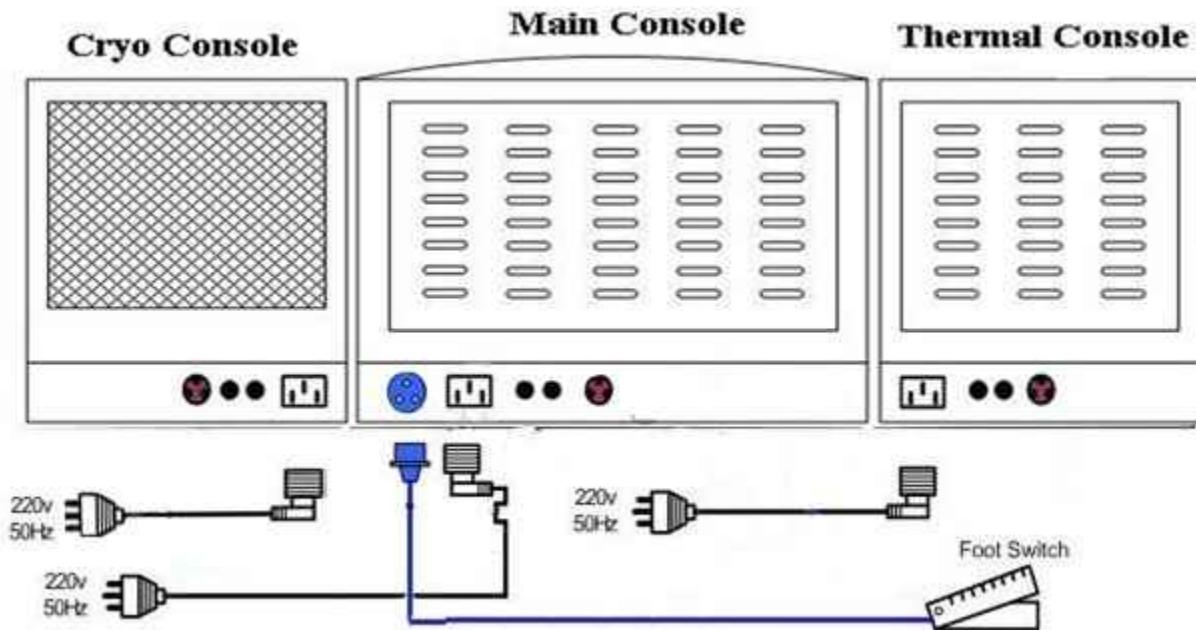



4.3 Start instruments

Turn on the power switch, on the display panel shows current time and company name (as following).



4.4 Setting temperature

Press  key, enters the setting temperature operation. using  key to move cursor to

select from No.1 to No. 5 heating parts, then press "OK" key to confirm the setting

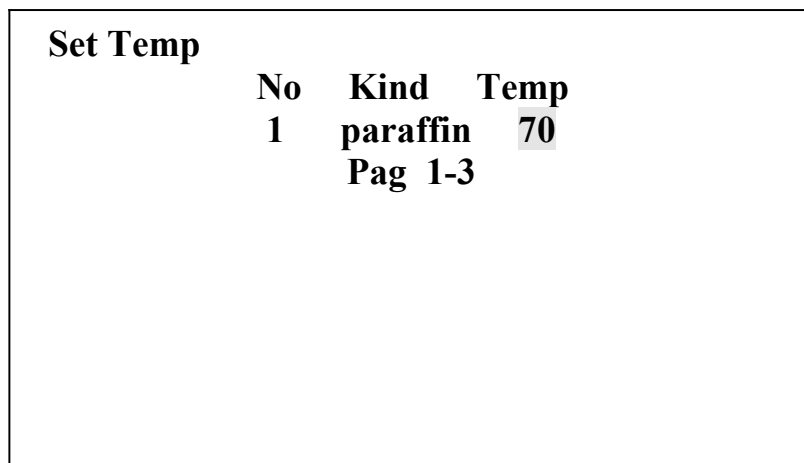

4.5 Adjust clock

Press the  key two times to enter into Set Clock interface, press  key to adjust the desired time.

Press "Ok" key to confirm the setting

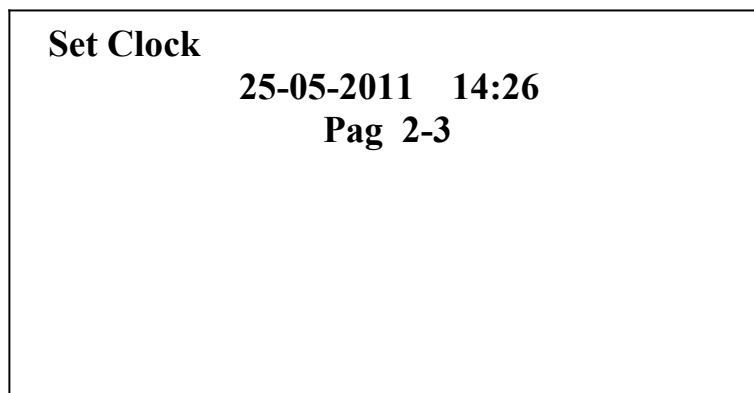

4.6 Setting automatic start time

(1) Press  key three times, enters the setting automatic start time operation. You will see, choose the automatic start time you need

No.	Start Time	ON/OFF
01	8.00 AM	
02	9.00AM	

Pag 3-3

OnON/OF
F

4.7 Manual heating

1) While the unit stays in standby mode, press the "ON/OFF" key to start the heating. Press the "ON/OFF" again, to stop the heating.



2) Using  key to change the cold spot to ON state ,then it start cooling; using



 key to change the cold spot to OFF state ,then it stop cooling.

14-06-2011	15:35
Paraffin tank	70
L-R Tray	70
Platform	60
Pag 1-2	

14-06-2011 **15:35**
Wax port 70
Forcep 70
Cold spot OFF
Pag 2-2

Note:

If Thermal Console or Cryo Console needn't use, it can turn off the switch separately.

4.8 Time heating



While the instrument stay in standby mode, it will start the instruments automatically according to the set time.

Note: During the heating states, if there isn't no any use within four hours, the instrument will switch off the heating, and enter the next automatic start time state.

4.9 Cryo Console Operation

4.91 Setting temperature

Turn on the power switch, on the display panel shows as following

Press  key to enter the set temperature interface. Press  or  till the desired temperature.

Press "Ok" key to confirm setting

Setting the temp
-18

4.10 Thermal Console Operation

The same operation steps, with the Cryo Console.

4. 11 Fuses range

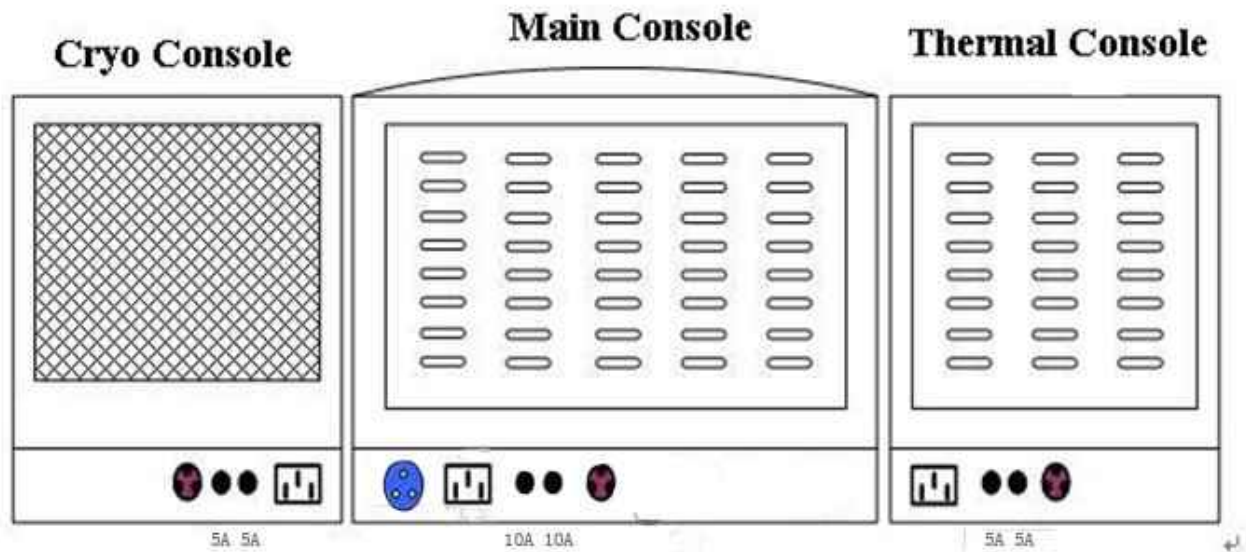

05 Troubleshooting

5.1 Main Console troubleshooting

(1) Replace heating parts and temperature sensor

a. Open the back board, to replace the paraffin tank heating part and temperature sensor.

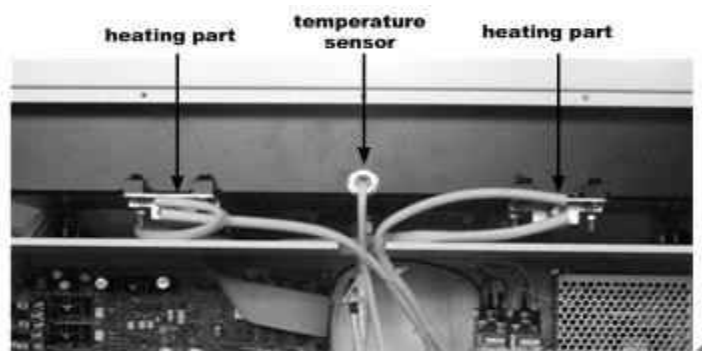

b. Open the soleplate, to replace left box, right box, platform heating parts, temperature

sensor and
electromagnetic valve heating parts

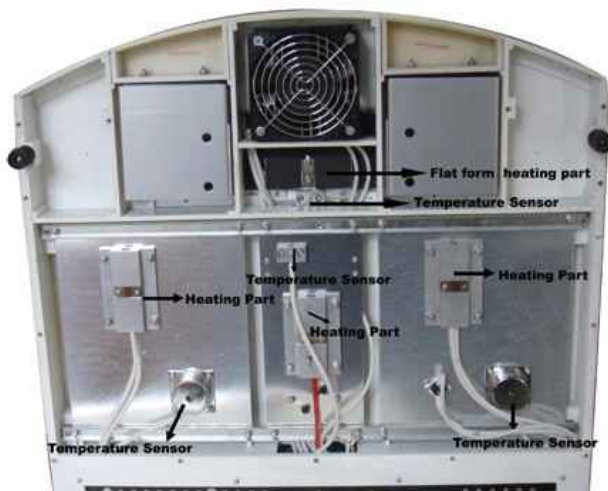

c. Open the cover of paraffin flow out lip, to replace the heating sensor and the electromagnetic valve.

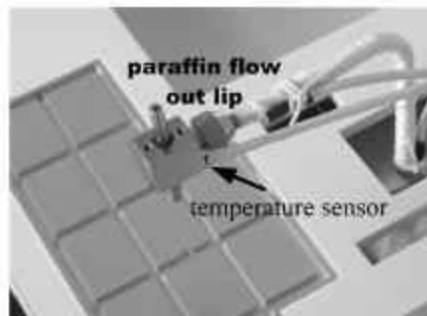
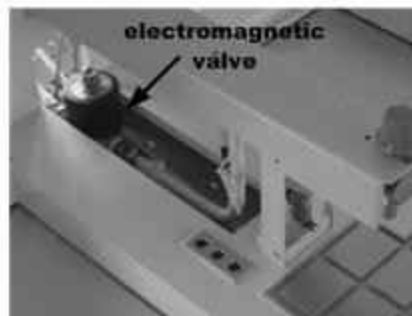

(2) Replace the fan for cooling and peliter.

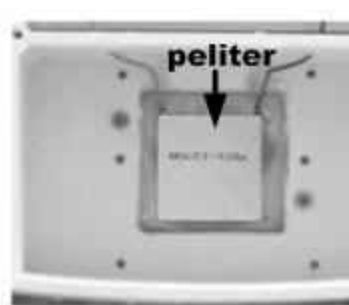

5.2 Thermal console troubleshooting

Open the soleplate, to replace the thermal console heating part and temperature sensor.



5.3 Cryo console troubleshooting

Open the soleplate, to replace the cryo console temperature sensor.

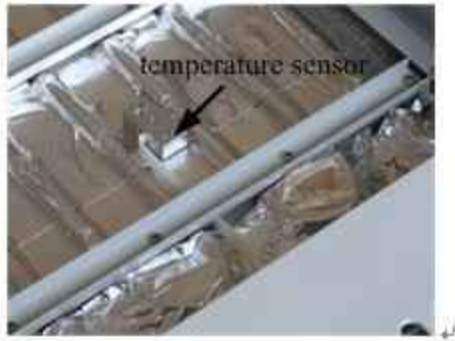

06 Maintenance

Keep the machine tidy and clean, and remove residual paraffin and dirt on the surface after work. Do not add too much paraffin to the left and right trays to prevent paraffin overflow which may cause damage to the parts and components. Do not use sharp and hard objects on the table surface to prevent scratch.



Email: contact@biolabscientific.com

Website: www.biolabscientific.com